

THIS DRAWING IS UNPUBLISHED. RELEASED FOR PUBLICATION
 © COPYRIGHT BY TYCO ELECTRONICS CORPORATION. ALL INTERNATIONAL RIGHTS RESERVED.

LOC	DIST	REVISIONS					
AF	50	P	LTR	DESCRIPTION	DATE	DWN	APVD
			C2	REVISED PER ECR-08-008189	24NOV08	HMR	DD

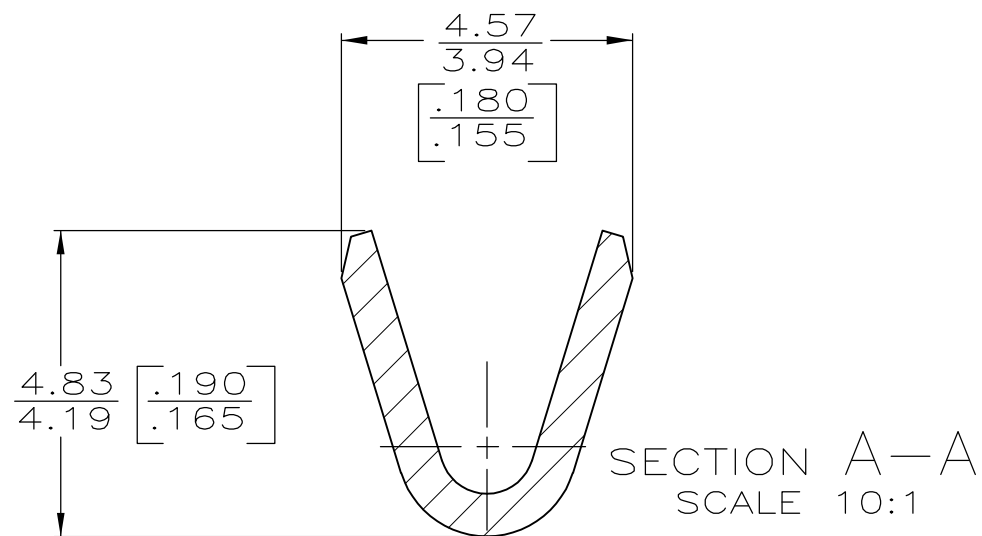
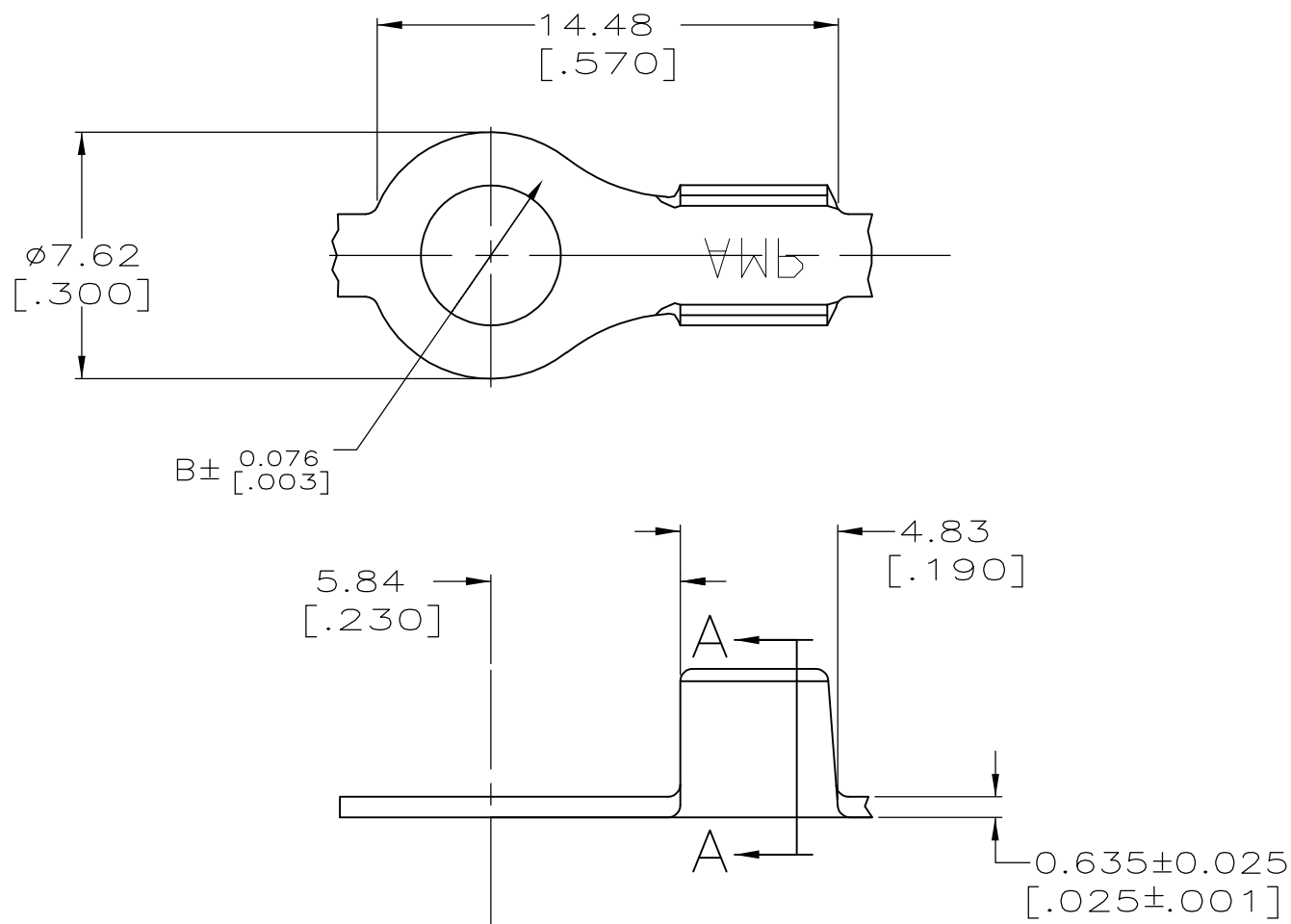

- 1 CONTINUOUS STRIP ON REELS.
- △2 TIN PLATING.
- 3 WIRE RANGE: 0.8–2.0mm² [18–14] AWG.
- △4 PACKAGED WITH INTERLEAVING PAPER.
- △5 PRELIMINARY – NOT FOR PRODUCTION.

△4	.171	△5	42111-4
	.197		42111-3
	.171		42111-2
	.145		42111-1
	B DIMENSION		PART NUMBER

F	3.56 [.140]	2.21 [.087] 2.03 [.080] 1.93 [.076]	2.0mm ² [14] 1.3mm ² [16] 0.8mm ² [18]
TYPE	WIDTH	±0.051 [±.002] HEIGHT	WIRE
WIRE BARREL CRIMP			

THIS DRAWING IS A CONTROLLED DOCUMENT.

DIMENSIONS: mm [INCHES]	TOLERANCES UNLESS OTHERWISE SPECIFIED:	DWN MICHAEL S. FEHER 9AUG2006	Tyco Electronics Corporation Harrisburg, PA 17105-3608
	0 PLC ± - 1 PLC ± - 2 PLC ± - 3 PLC ± 0.38 [.015] 4 PLC ± - ANGLES ± -	CHK DONALD F. DECKER 09AUG2006 APVD DONALD F. DECKER 09AUG2006	
MATERIAL #1 HARD BRASS	FINISH △2	PRODUCT SPEC -	NAME RING
		APPLICATION SPEC -	SIZE A3
		WEIGHT -	CAGE CODE 00779
		CUSTOMER DRAWING	DRAWING NO C-42111
		SCALE 5:1	RESTRICTED TO -
		SHEET 1 OF 1	REV C2